

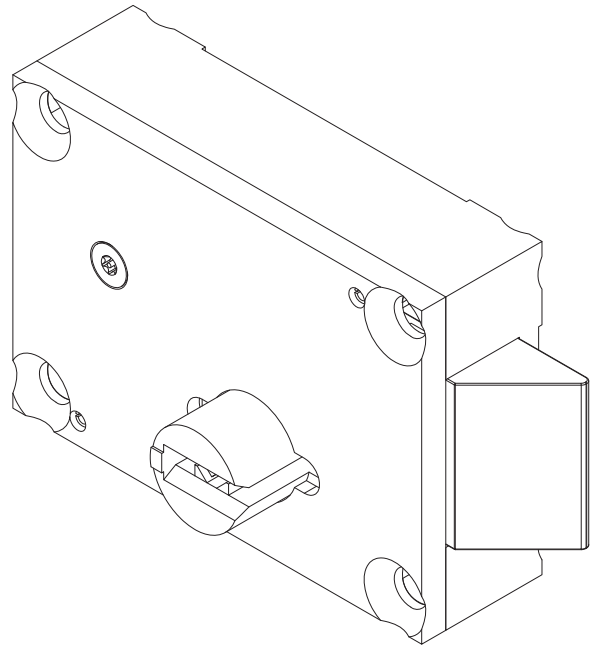

## WLS-1717 Stainless Steel Food Pass Lock



### Recommended Specifications

The WLS-1717 series lock is used in high security applications for food pass doors, observation panels and other small doors in Governmental and Industrial buildings. The WLS-1717 series uses a paracentric cylinder and key.

The WLS-1717 is not recommended as a primary means of securing a full door or when dead latching is a requirement.

#### **Standard lock shall include:**

- High security and impact resistant
- 1/2" latch throw
- Latch size is 1-1/2" x 3/4"
- Lock case, cover and latch are constructed from cast stainless steel utilizing hardened brass key, cylinder and tumblers
- Lever tumblers are designed with 'anti-pick' notches for both the locked and unlocked positions
- Key-way depths are designed to impede of 'picking' of locks
- Key is made of bronze alloy and machined to fit smoothly into lock (sold separately)
- Lock is mounted with 4 security screws (included with lock)
- Standard handing is Right Hand (RH) for food pass.

**To specify fixture and accessories, use the Model Number and Options page.**

Example: To specify a food pass stainless steel lock, and keyed one side.

Use the following Willoughby Model Number:  
**WLS-1717-K1**



**WARNING:** Cancer and Reproductive Harm

- [www.P65Warnings.ca.gov](http://www.P65Warnings.ca.gov)

visit our website at [www.willoughbylocks.com](http://www.willoughbylocks.com)  
5105 West 78th Street • Indianapolis, IN. 46268  
(317) 875-0830 • Fax: (317) 875-0837 • (800) 428-4065



MADE IN THE U.S.A.

# MODEL NUMBER AND OPTIONS:

## 1.) Model Number:

WLS-1717 Stainless Steel Food Pass Lock

## 2) Keyed:

K1 Keyed One Side

K2 Keyed Both Sides

Other \_\_\_\_\_

## 3) Extended bolt:

EXB 1" Extended Bolt

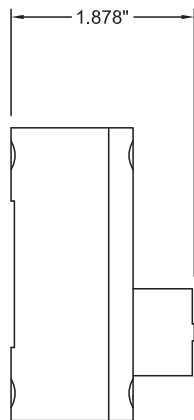
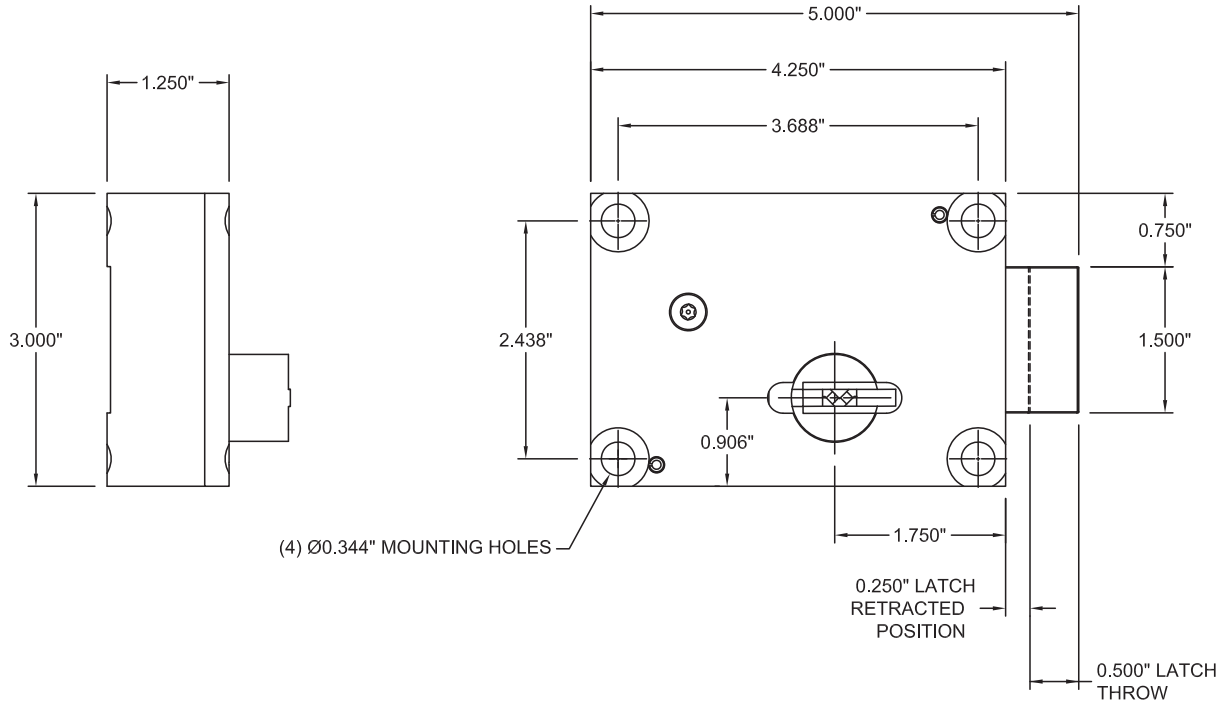

**K1**

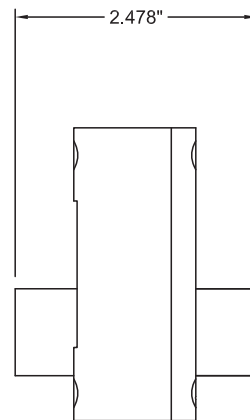

**K2**

**DRAWINGS ARE FOR REFERENCE ONLY, CONTACT FACTORY TO VERIFY DIMENSIONS**

WILLOUGHBY RESERVES THE RIGHT TO MAKE CHANGES IN DESIGN AND DIMENSIONS WITHOUT FORMAL NOTICE AND WITHOUT INCURRING OBLIGATION.

visit our website at [www.willoughbylocks.com](http://www.willoughbylocks.com)

5105 West 78th Street • Indianapolis, IN. 46268

(317) 875-0830 • Fax: (317) 875-0837 • (800) 428-4065



MADE IN THE U.S.A.

**ADDITIONAL INFORMATION:**

**LOCK HANDING CHART**

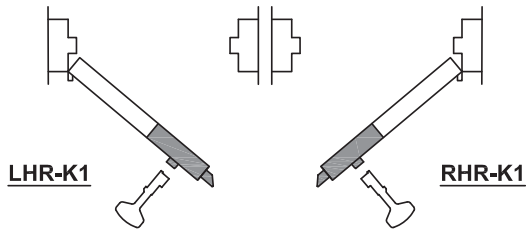

**KEYED K1 HINGED SIDE**  
HOLLOW METAL MOUNTING PLATE  
(FOR OUT-SWING DOORS)

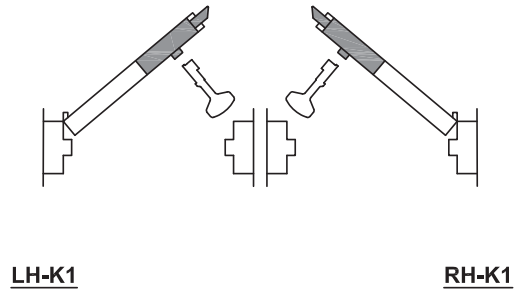

**KEYED K1 STOP SIDE**  
HOLLOW METAL MOUNTING PLATE  
(FOR IN-SWING DOORS)

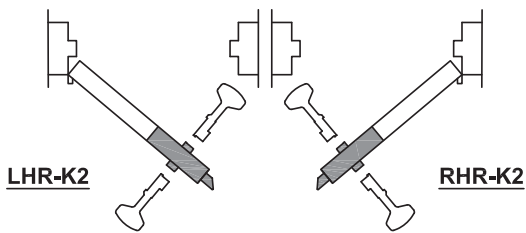

**KEYED K2**  
HOLLOW METAL MOUNTING PLATE  
(FOR OUT-SWING DOORS)

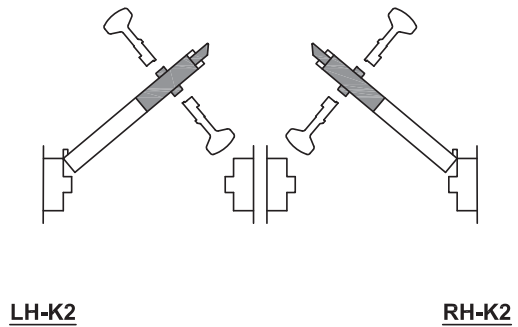

**KEYED K2**  
HOLLOW METAL MOUNTING PLATE  
(FOR IN-SWING DOORS)

---

visit our website at [www.willoughbylocks.com](http://www.willoughbylocks.com)  
5105 West 78th Street • Indianapolis, IN. 46268  
(317) 875-0830 • Fax: (317) 875-0837 • (800) 428-4065



MADE IN THE U.S.A.