

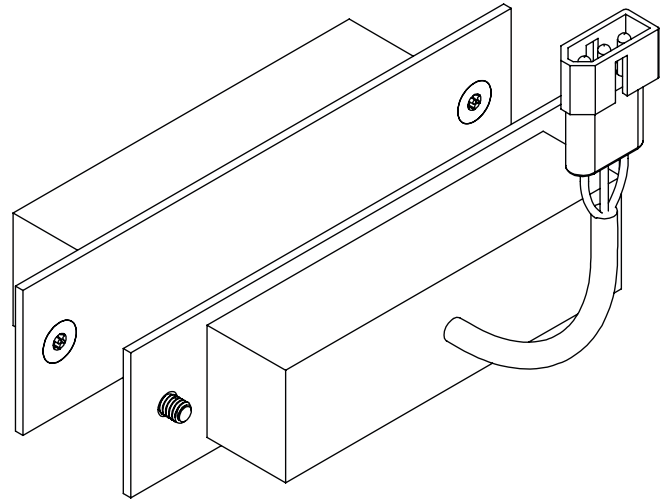

WLS-DPS Series Magnetic Door Position Switch



Recommended Specifications

Application:

The WLS-DPS series magnetic door position switch is used to confirm that a door is closed, enhancing the accuracy of lock control systems. It ensures a door must be closed to signal a secure status or allow other doors to be unlocked. The DPS is essential for precise monitoring and control of door security, preventing compromises in system. A DPS must be combined with lock status switch (LSS) to ensure accuracy of open/closed status.

Standard unit shall include:

- Secure and impact resistant
- Stainless steel body
- Magnet with sensors

To specify fixture and accessories, use the Model Number and Options page.

Example: To specify a magnetic door position switch, magnetically actuated, mortise mounted

Use the following Willoughby Model Number:
WLS-DPS



WARNING: Cancer and Reproductive Harm

- www.P65Warnings.ca.gov

visit our website at www.willoughbylocks.com
5105 West 78th Street • Indianapolis, IN. 46268
(317) 875-0830 • Fax: (317) 875-0837 • (800) 428-4065



MADE IN THE U.S.A.

MODEL NUMBER AND OPTIONS:

1.) Model Number:

☐ WLS-DPS Series Magnetically Door Position Switch, Magnetically Actuated, Mortise Mounted

2.) Options:

☐ TB Triple Biased, Magnetically Actuated, Mortise Mounted

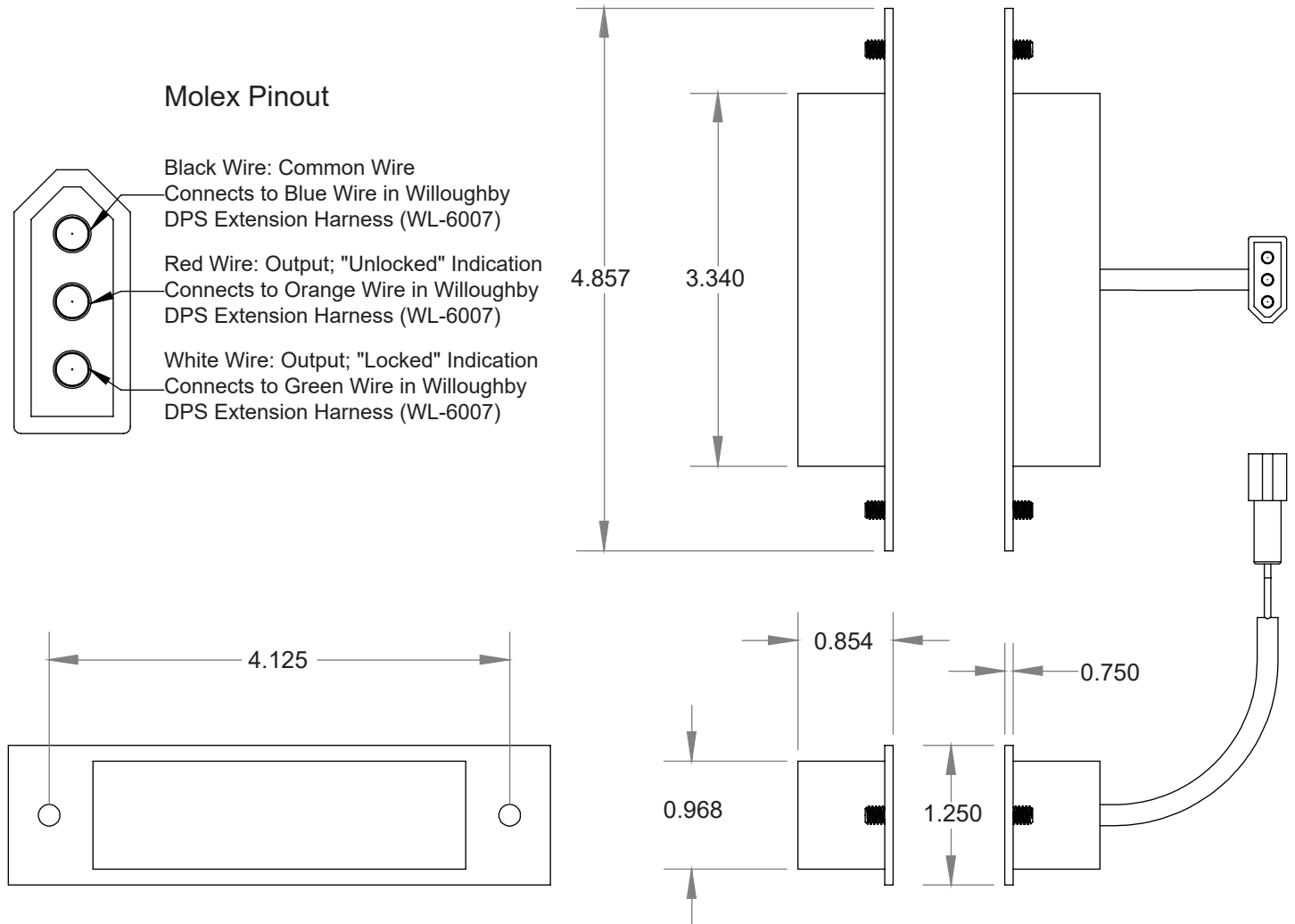

DRAWINGS ARE FOR REFERENCE ONLY, CONTACT FACTORY TO VERIFY DIMENSIONS
WILLOUGHBY RESERVES THE RIGHT TO MAKE CHANGES IN DESIGN AND DIMENSIONS WITHOUT FORMAL NOTICE AND WITHOUT INCURRING OBLIGATION.

visit our website at www.willoughbylocks.com
5105 West 78th Street • Indianapolis, IN. 46268
(317) 875-0830 • Fax: (317) 875-0837 • (800) 428-4065



MADE IN THE U.S.A.