

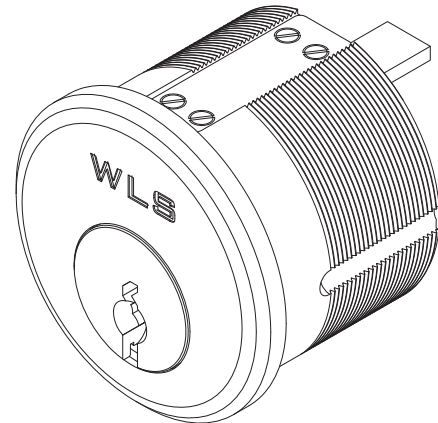

WLS-TDM True Detention Mogul Cylinder



Recommended Specifications

Application:

The WLS-TDM series Mogul cylinder is designed for use in high security applications. The WLS-TDM is a true Detention Mogul Cylinder, providing the highest level of security and durability. It is designed to inhibit many security concerns including picking, bumping, impact, and drilling. The cylinder, pins, drivers, springs, and internal barrings are all constructed of stainless steel.

Standard unit shall include:

- Secure and impact resistant
- Rekeyable in field
- Stainless steel body
- Stainless steel integral components
- Stainless steel actuator cam

Certifications:

- U.L. 437 Listed
- ASTM F 1577 6.6 3rd Party Certified

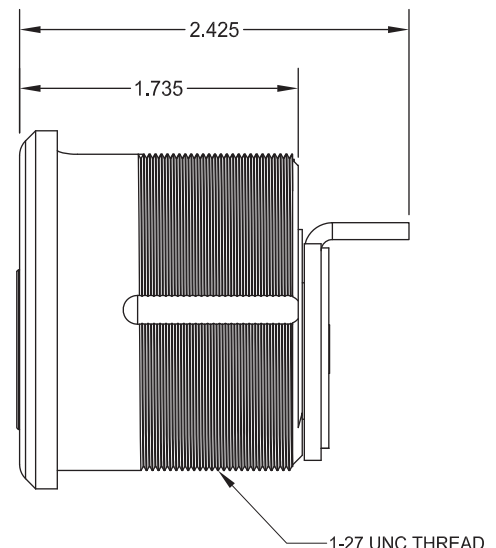
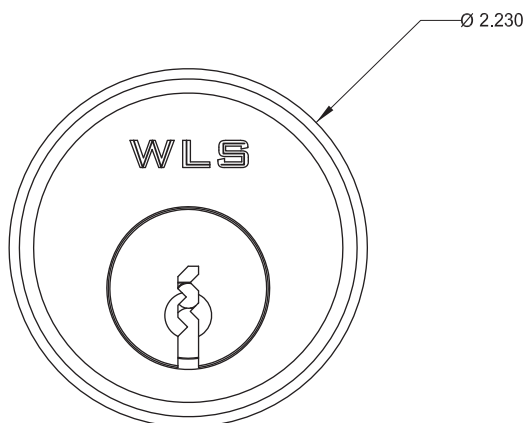

WARNING: Cancer and Reproductive Harm

- www.P65Warnings.ca.gov

visit our website at www.willoughbylocks.com
5105 West 78th Street • Indianapolis, IN. 46268
(317) 875-0830 • Fax: (317) 875-0837 • (800) 428-4065



MADE IN THE U.S.A.